

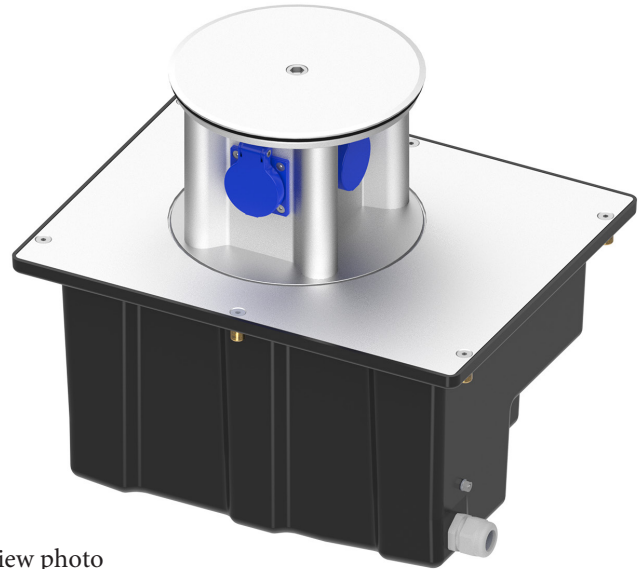

PRODUCT DATA SHEET

PAGE 1/2

TerraMo - compact underfloor distributor
Item no. M502010002

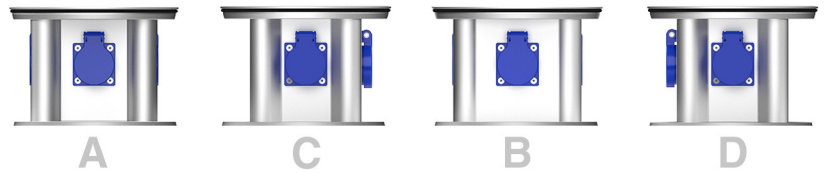

preview photo

TECHNICAL DATA

Dimensions:	303x390x309mm (WxDxH)
Installation depth:	303mm
Extending height:	136mm
Load capacity:	max. driveable by car
Material device column:	Aluminum, anodized E6/EV1
Material base tub:	Polyethylene
Ingress protection:	IP44 sockets / IP55 distribution modules
Protection class:	I
Equipment:	4 x Protective contact socket 16A 2P+E 230V
max. back-up fuse:	16A
Power supply terminals:	5x6qmm
Weight:	approx. 11kg



PRODUCT DATA SHEET

PAGE 2/2

DIMENSIONS

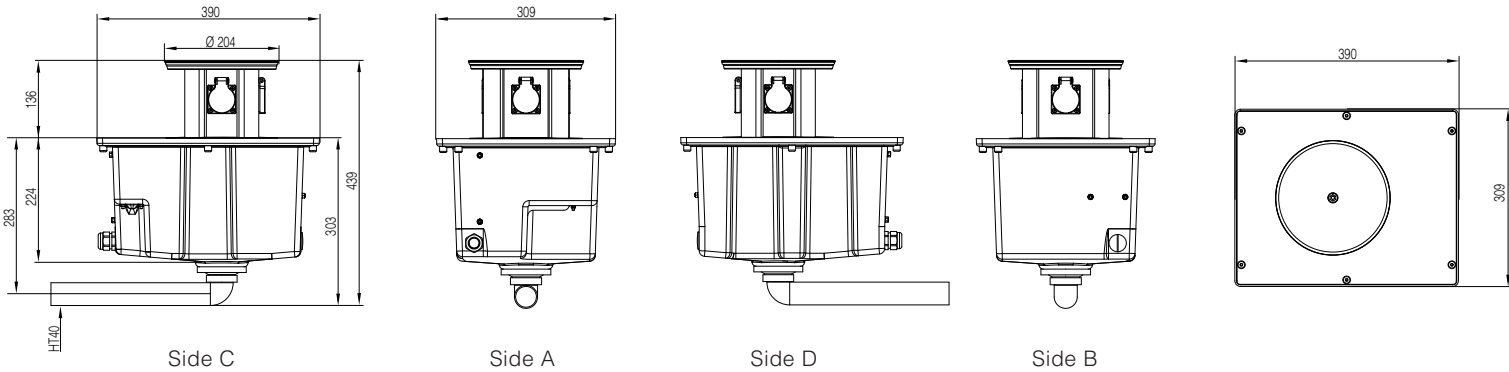

All dimensions in millimeter.

WIRING DIAGRAM

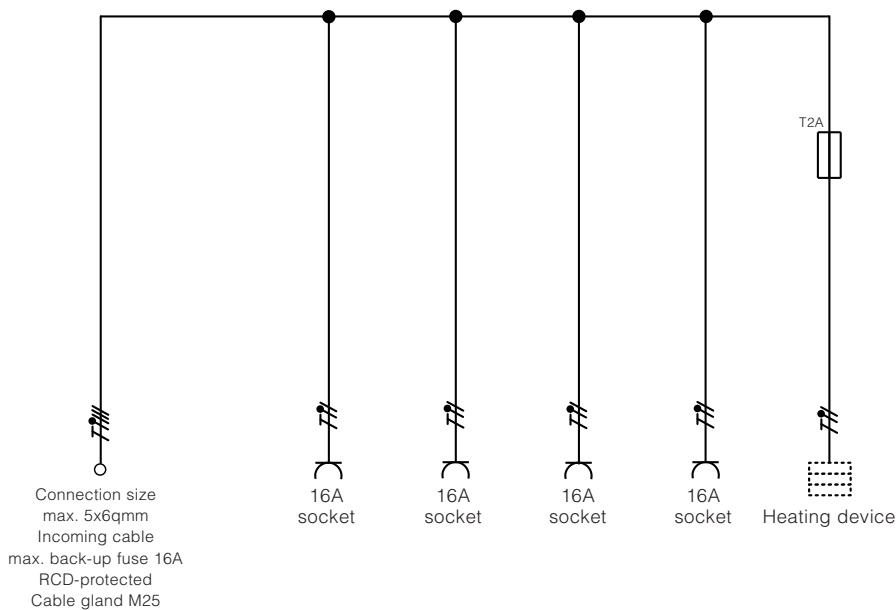

Modifications and errors excepted. No liability accepted for printing errors.
Our terms of delivery and payment apply.